

Lamb

D R A F T

Page Mode Write Protect Up-grade Kit for RAM B

Installation of the up-grade kit for RAM B will enhance the memory board by providing the following functions:-

1. The ability to write protect each of the 16K blocks via toggle switches provided on the Pcb. The status of each of these switches is indicated by LED
2. A switch is provided to allocate to any particular card one of 4 page numbers 0 - 3

Installation of the Up-grade Kit

If the card is in the process of being built, the manual for the memory card should be read in conjunction with this note and the appropriate links made.

Step 1. First check that you have a complete set of parts as per the Parts List and ensure that each of them has been correctly identified. Please report any discrepancy immediately to the retailer who sold you the unit.

Step 2. If you are modifying an already built card, one link will require insertion, two links will require modification and 3 will require removal. If you are building a new card, follow the step in the manual for the up-grade.

- a) Link 7 - make this link
- b) Link 5 - this should now go from 2 to C
- c) Link 6 should now go from 1 to C
- d) Remove the 3 links which have been installed in the switch positions.

Step 3. Now insert and solder the 3 toggle switches and DIL switch. Next solder in the 3 red LEDS (Led 1, 2, and 3) with the lead from the notched side going to the round hole. Users may find it convenient to bend the leads to 90° and mound the LED's so that the optimum of viewing position is along the plain of the board.

Next solder in the green LED to the LED 4 position

Next instal the following I.C's in the following positions:-

CA 3046 should go into 42

74LS30 should go into 43

74LS32 should go into 44

74LS273 should go into 45

Your board is now complete and ready for testing.

The following points should be borne in mind:-

1. No two boards whose address space overlap should be given the same page number

2. When the system is reset, Page 0 will be activated.

3. It is possible to active more than one board for WRITE. However, the user should not try and read more than one board simultaneously as a BUS contention will occur leading more than likely to a system crash.

4. Your Nascom should ~~not~~ be set to an external port de code as the Page Mode feature utilises Port FF.

5. Operation of the Page Mode facility

The page is allocated to a board according to the position of the DIL switch. Once the boards have been given their appropriate page numbers the read section and the write section of each board can be individually enabled by writing the appropriate number to Port FF. It should be noted that this is a write only port and the status cannot be read back from it. The least significant fours bits of the binary number written to Port FF control in turn pages the read enabled of Pages 0-3 inclusive. The 4 most significant digits of the binary number written to Port FF controls write enabled of cards 0-3 inclusive. For example if hexadecimal number 1. 1 i.e. 11 is written to Port FF page 0 will be enabled for both read and write modes.

If for example 20 H is written to Port FF, the board allocated page No. 1 will be write enabled and the board allocated page 0 will be in read enabled. If for example F4 was written to Port FF pages 0 - 3 inclusive will be write enabled and Page 3 will be read enabled.

Use the NAS-SYS "O" command to output to Port FF.

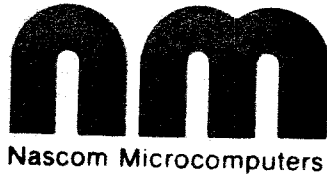

11.12.81

PAGEMODE KIT PARTS LIST

QTY	ITEM	REF
1	74 LS 30 8 Input Nand Gate	IC 43
1	74 LS 32 QUAD 2 Input or Gate	IC 44
1	74 LS 273 OCTAL D Type Flip Flop	IG 45
1	CA 3046 NPM Transistor array	IC 42
1	0.2" Green LED	LED 4
3	0.2" Red LED	LED 1 to 3
1	DS 16A 2-4 Switch	SW4
1	Nylon Dust Cover (For SW4)	
3	PCB Mounting and SPDT Toggle switch	SW1 to SW3
4	220R $\frac{1}{4}$ w Resistors	R10 to R13

- (a) For the circuit diagram refer to Fig 11 of the RAM B Manual.
- (b) The links required are shown in Fig 6 of the manual.
- (c) The square pad for LED 1 to 4 represents the anode. (This is shown as the pin without the flat on the body and with the shorter leg).

Fig. 11 Memory Page-mode logic

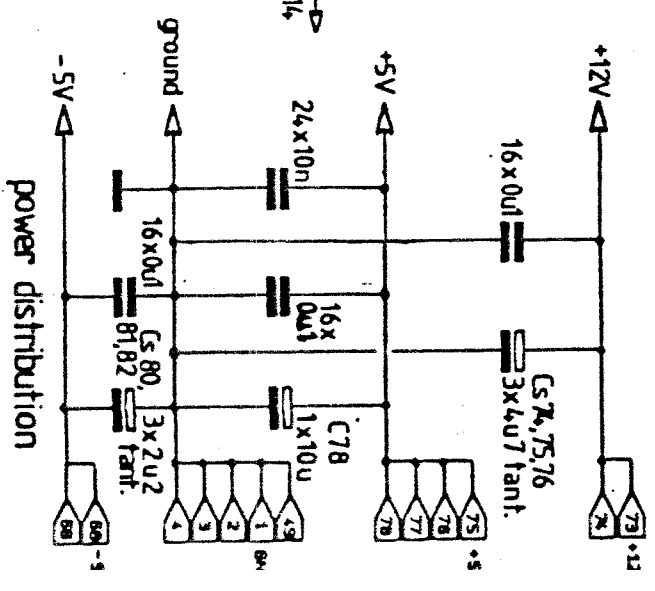
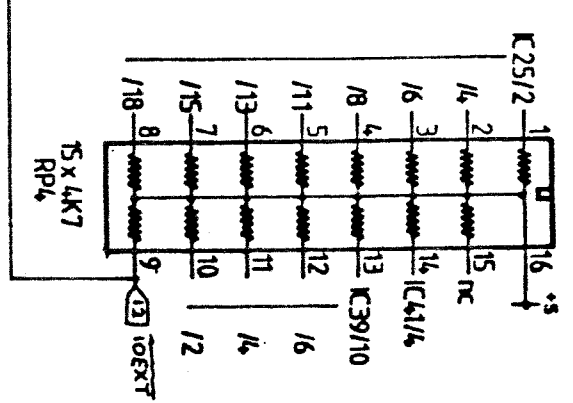
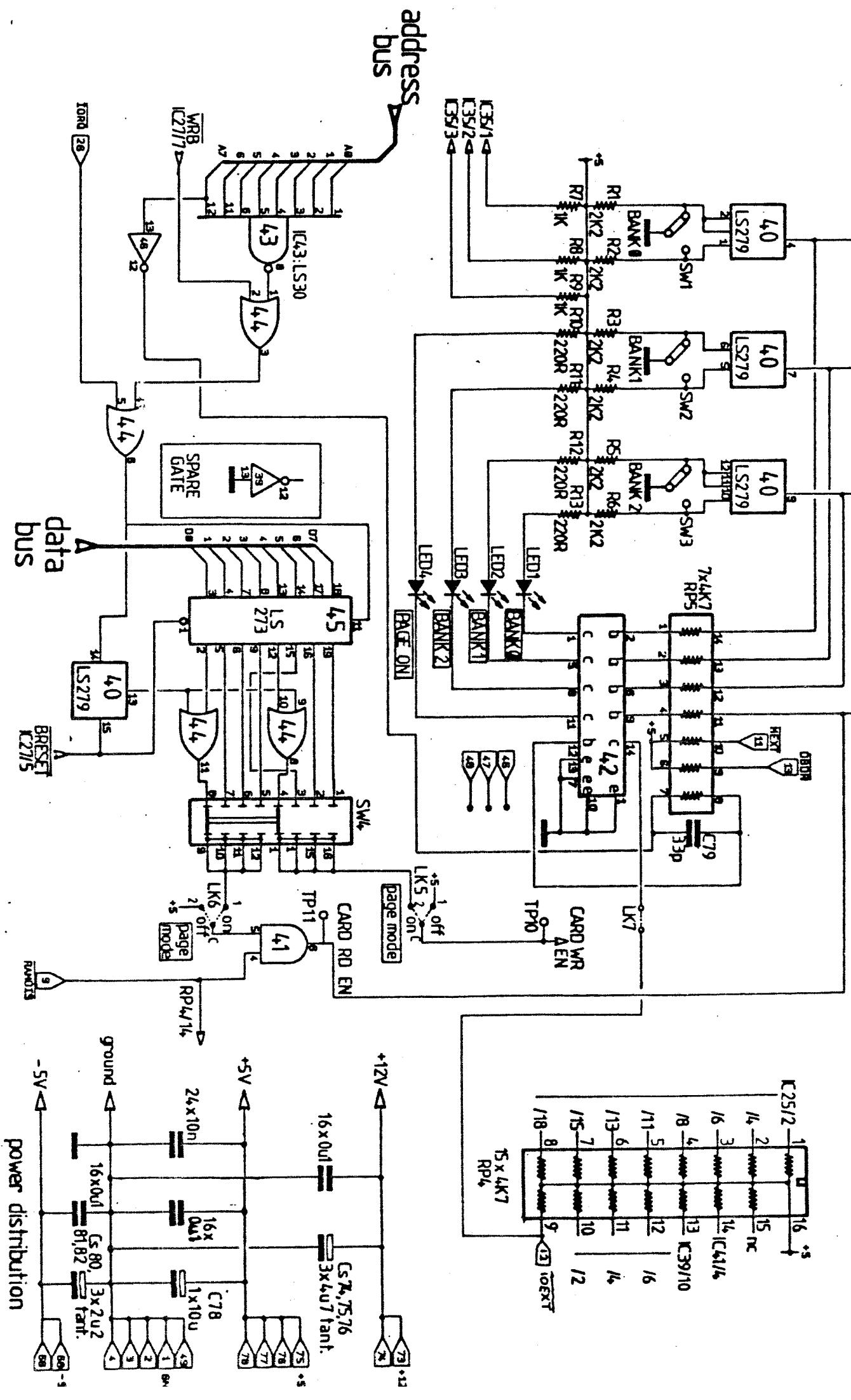

NASCOM microcomputers Ltd.

type (b) RAM board [2]

NIM no	024-401	date	22-04-80	issue
drawn	<i>dar</i>	checked	<i>NS</i>	2

9. PAGE MODE LINKS (LK5 to 6)

fig.6

WR.EN
LK5

Page mode not
installed 1

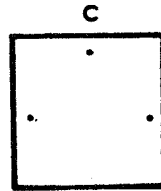

2 Page mode
installed

RD.EN
LK6

Page mode
installed 1

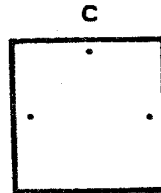

2 Page mode not
installed

I/O EXT
LK7

Page mode
installed



Page mode not
installed
(no link)